

Rev	Date	Modified by	Description
A0	2023		

Product Specifications

GPON Class C+ SFP OLT Transceiver

PN: EGP4321-3SCDC2

Features

- SFP with SC/PC Connector Transceiver
- 1490 nm DFB Tx with isolator
- 1310 nm APD Rx
- Digital diagnostics SFF-8472 Compliant
- 2488 Mbps continuous mode Transmission
- 1244 Mbps Burst mode receiver Data Rate
- RX Fast Burst Mode Detection
- Provide fast RSSI function
- Operation case temperature: 0~70° C
- Class C+ link budget
- Comply with ITU-T G984.2 Amendment 1
- Complies with RoHS directive (2002/95/EC)

Application

- GPON OLT Class C+
- FTTx

Function Diagram

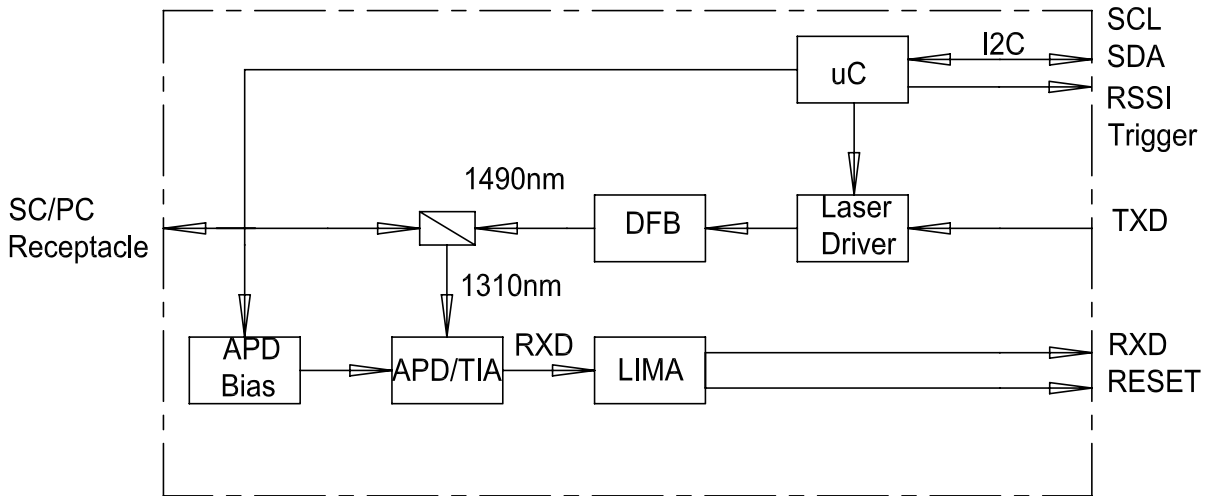

Recommended Operating Conditions

Parameter	Symbol	Min.	Max.	Unit
Storage Temperature	T_{STG}	-40	85	°C
Operating Case Temperature	T_C	0	70	°C
Power Supply Voltage	V_{CC}	3.1	3.5	V
Total Power Supply Current	I_{CC}	-	500	mA

Transmitter Characteristics

Parameter	Symbol	Min.	Typ.	Max.	Units	Notes
Optical Transmitter Power	P0	+3	-	+7	dBm	1
Optical Transmitter Power off	POFF	-	-	-39	dBm	
Output Center Wavelength	λ	1480	-	1500	nm	
Output Spectrum Width	$\Delta\lambda$	-	-	1.0	nm	
Side Mode Suppression Ratio	SMSR	30	-	-	dB	
Extinction Ratio	ER	8.2	-	-	dB	
Optical Rise Time	-	-	-	160	ps	
Optical Fall Time	-	-	-	160	ps	

Optical Eye Diagram	Compliant with ITU-T G.984.2 Mask				
Tolerance to Tx Back Reflection	-	-15	-	-	dB
Data Rate	-	-	2.488	-	Gb/s
Differential Input Voltage	V _{PP}	300	-	1200	mV
Differential Input Impedance	Z _{IN}	80	100	120	ohm
Tx_fault Output Voltage- High	V _{IH}	2.4	-	-	V
Tx_fault Output Voltage- Low	V _{IL}	-	-	0.4	V
Tx_Dis Input Voltage- High	V _{IH}	2.0	-	-	V
Tx_Dis Input Voltage- Low	V _{IL}	-	-	0.8	V

Note 1: 2.488Gbps continuous-mode , PRBS²³-1.

Receiver Characteristics

Parameter	Symbol	Min.	Typ.	Max.	Units	Notes
Wavelength of Operation	-	1260	-	1360	nm	-
Data Rate	-	-	1.244	-	Gb/s	-
Sensitivity	Sen	-	-	-30	dBm	1
Saturation Optical Power	Sat	-12	-	-	dBm	1
Receiver Reflectance	-	-	-	-12	dB	
Receiver Burst-mode Dynamic Range	-	15	-	-	dB	2
Data Output Voltage - High	V _{OH}	V _{ccR} -1.05	-	V _{ccR} -0.85	V	-
Data Output Voltage - Low	V _{OL}	V _{ccR} -1.84	-	V _{ccR} -1.60	V	-
Data Output Differential Swing	-	400	-	1600	mV	
RSSI accuracy	-	-3	-	3	dB	3
BPD Output Voltage- High	V _{IH}	2.4	-	-	V	4
BPD Output Voltage- Low	V _{IL}	-	-	0.4	V	4
Guard Time	T _{GUARD}	-	32	-	bits	-
Rest Width	T _{RESET}		16	-	bits	
Optical Signal During Time	T _{ONTEN_DUR}	300	-	-	ns	5
RSSI Trigger Delay	T _D	0	-	3000	Ns	6
RSSI Trigger Width	T _w	300	-	T _{ONTEN_DUR}	ns	

Note 1: Measured with 1310nm, 1.244Gbps PRBS²³-1 burst-mode optical input, ER=10dB,

BER=1x10⁻¹⁰; Single burst packet length is 40us and packet interval is 40us.

Note 2: Input optical power level difference of adjacent burst packets.

Note 3: Receiver optical power ranged from -8dBm to -28dBm, measured with 1310nm,

1.244Gbps PRBS⁷-1 burst-mode optical input, ER=10dB, 50%duty cycle.

Note 4: BPD assert low when module receive "Reset" signal, assert high when burst package

is detected and latch to high state until next "Reset" signal.

Note 5: For RSSI Measurement

Note 6: Refer to first bit of the preamble

Burst Mode Receiver Dynamic Range

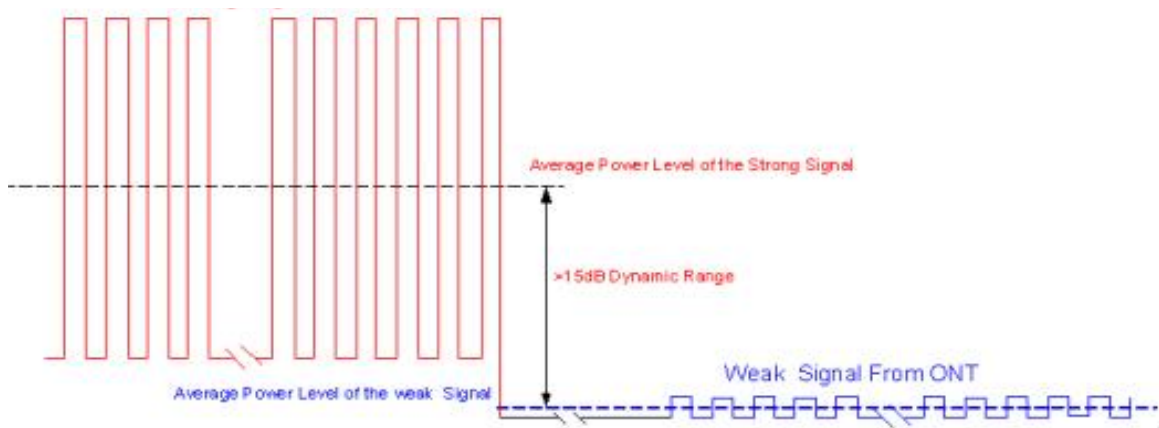

Timing Parameter Definitions in Burst Mode Sequence

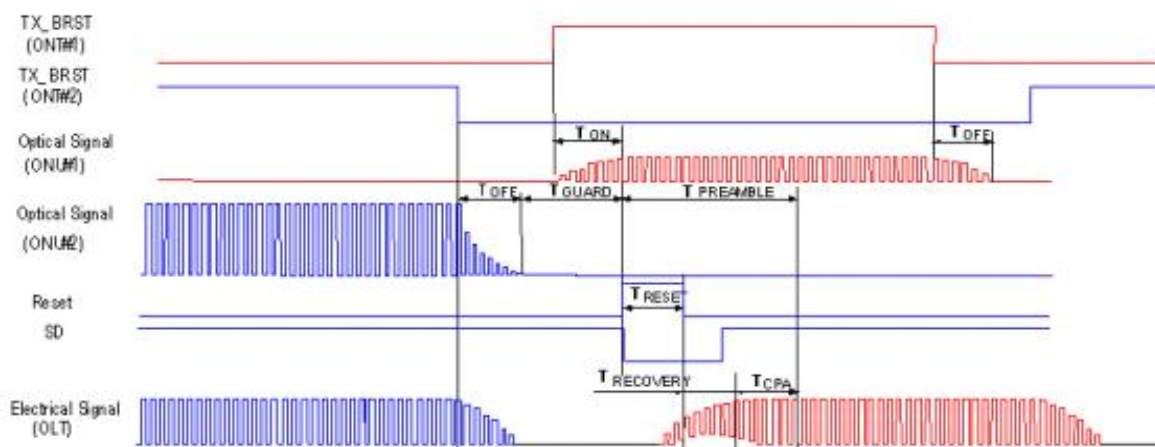

RSSI Timing Sequence

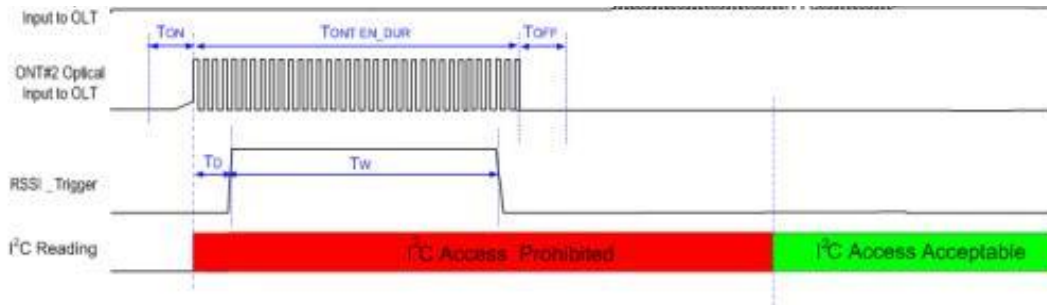

Digital Diagnostic Monitoring Accuracy

Parameter	Accuracy	Units	Notes
Transceiver Temperature	±3	°C	Temperature sensor
Power Supply Voltage	±3	%	Vcc=3.13~3.47V
TX Bias Current	±10	mA	
TX Optical Power	±3	dB	Average Power
Rx Power	±3	dB	

Pin Definitions

Pin#	Name	Function
1	VeeT	Transmitter Ground
2	TX_Fault	Transmitter Fault Indication, LVTTTL Output, Active High
3	TX_Disable	Transmitter Disable, LVTTTL Input. Optical output power is off when this PIN is high or left unconnected.
4	SDA	I2C Data
5	SCL	I2C Clock
6	MOD-DEF(0)	Internally grounded

7	Reset	Receiver Reset , LVTTTL Input. Set "Reset" high at the end of previous burst, 2 bytes in duration
8	BPD	Burst Packet Detect, LVTTTL output. BPD assert low when module receives "reset" signal, assert high when incoming burst is present.
9	RSSI_Trigger	RSSI Trigger Signal from Host, LVTTTL input.
10	VeeR	Receiver Ground
11	VeeR	Receiver Ground
12	RD-	Inv. Received Data Out, LVPECL,DC coupled
13	RD+	Received Data Out, LVPECL,DC coupled
14	VeeR	Receiver Ground
15	VccR	Receiver Power
16	VccT	Transmitter Power
17	VeeT	Transmitter Ground
18	TD+	Transmit Data In, LVPECL or CML (AC coupled; internally 100 ohms differential termination)
19	TD-	Inv. Transmit Data In, LVPECL or CML (AC coupled; internally 100 ohms differential termination)
20	VeeT	Transmitter Ground

Outline Drawing

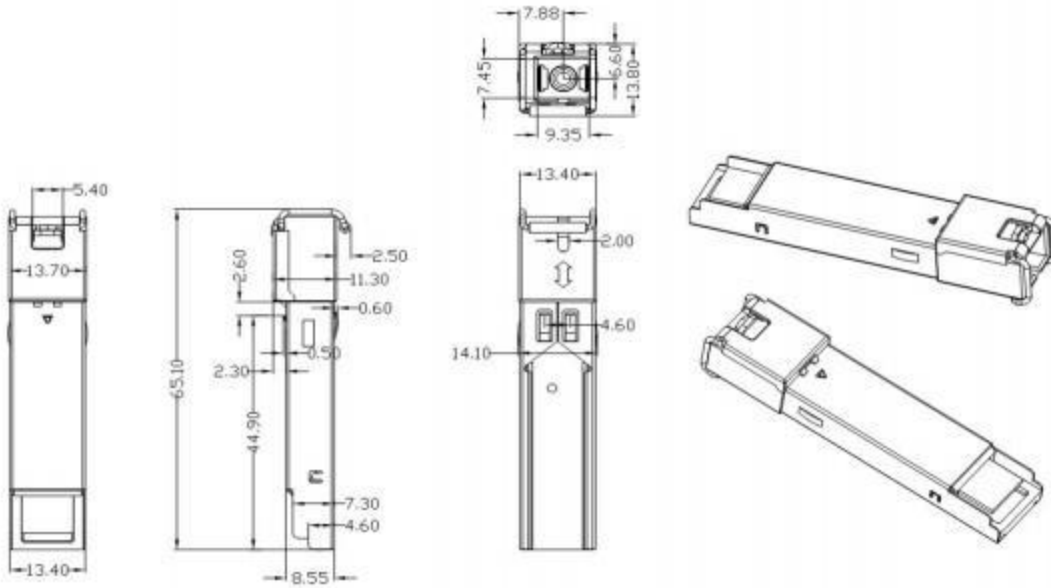

Unit:mm

Recommended Application Circuit

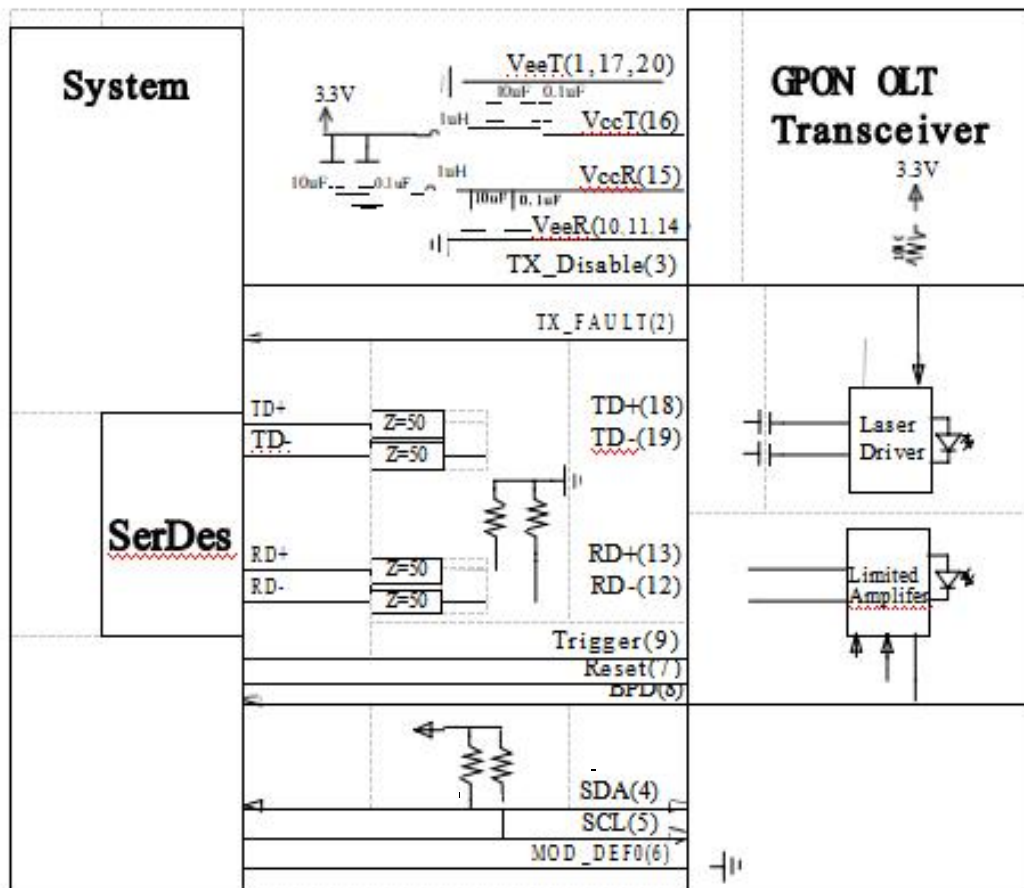

Compatibility Test

In order to ensure the product compatibility, our products will be tested on the switch before shipment. Our modules can compatible with many mainstream brand switches, such as Cisco, Juniper, Extreme, Brocade, IBM, H3C, HP, Huawei, D-Link, Mikrotik, ZTE, TP-Link...

Our test equipment: VOLKTEK MEN-4110, HP 2530-8G, CRS226-24G-25+RM, Catalyst 2960G Series, Catalyst 3850 XS 10G SFP+, Catalyst 3750-E Series, HUAWEI S5700Series, H3C S3100V2 Series, Juniper-EX4200, etc.



HUAWEI S6720S

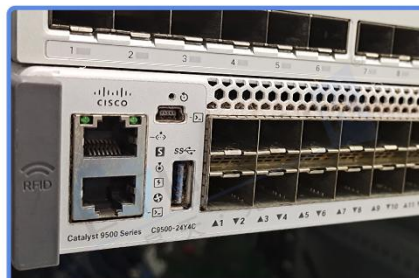

CISCO Catalyst 9500



DELL S5048F



H3C S3100V2

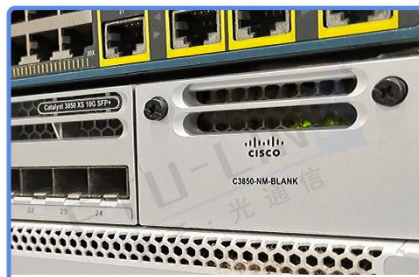

CISCO C3850



Aruba 2930F



Juniper EX 4200



HP J9264A

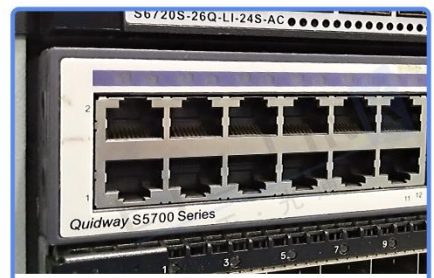

Quidway S5700

Product Production Process

Quality Assurance

Continuous introduction of new equipment,
produced by strict standards, strict quality inspection,
to guarantee the high quality standard of each product.

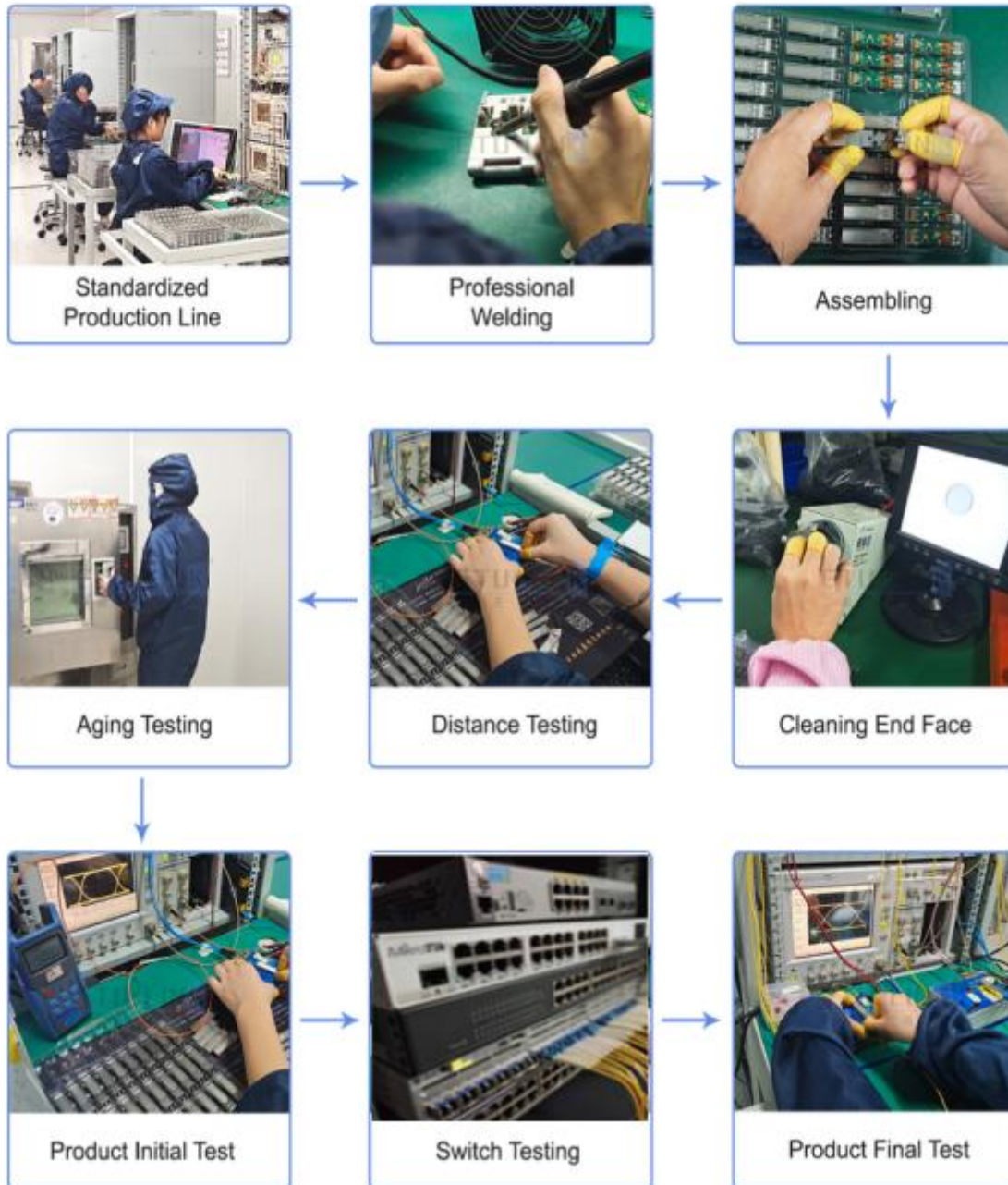

Packaging

ETU-Link provides two kinds of packaging, 10pcs/Tray and individual package.



Company: ETU-Link Technology Co., LTD

Address: Right side of 3rd floor, No. 102 building, Longguan expressway, Dalang street,
Longhua District, Shenzhen city, Guangdong Province, China 518109

Tel: +86-755 2328 4603

Addresses and phone number also have been listed at www.etulinktechnology.com.

Please e-mail us at sales@etulinktechnology.com or call us for assistance.